



TROXNETCOM

Functional module LON-WA1/FT3

For the control of up to four damper actuators

For use in LON networks

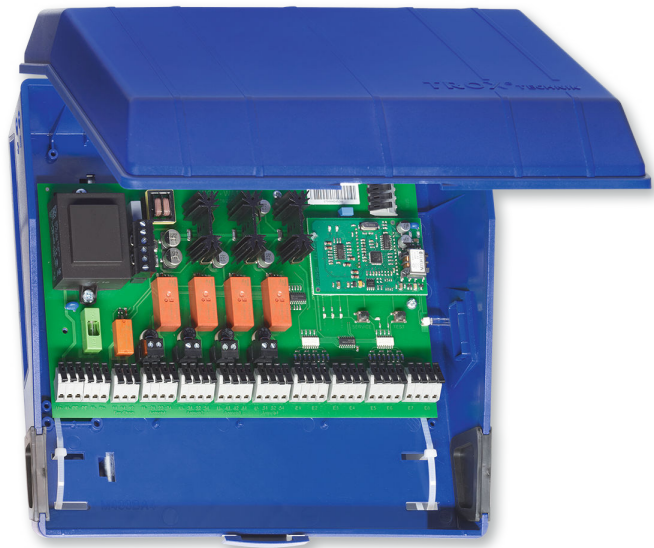

TROX[®] TECHNIK

The art of handling air

TROX GmbH

Heinrich-Trox-Platz
47504 Neukirchen-Vluyn, Germany
Germany

Telephone: +49 2845 202-0

Fax: +49 2845 202 265

email: trox@trox.de

Internet: www.troxtechnik.com

Translation of the original

A00000045598, 2, GB/en

03/2020

© TROX GmbH 2018

1	General	4	Configuration parameters.....	20	
	About this manual.....	4	Configuration with the LonMaker® plug-in.....	23	
	Symbols used in this manual.....	4	Installing the plug-in.....	23	
	Limitation of liability.....	5	Starting the plug-in.....	23	
	Copyright.....	5	Configuring the module.....	24	
	Replacement parts.....	5	9	Removal and disposal	29
	Defects liability.....	5	10	Index	0
	Customer service.....	6			
2	Security	6			
	Dangers and risks.....	6			
	Correct use.....	7			
	Incorrect use.....	7			
	Residual risks.....	7			
	Qualified staff.....	7			
3	Transport and installation	8			
	Transport.....	8			
	Storage.....	8			
4	Structure and functional description	9			
	Functional description.....	10			
5	Technical data	12			
6	Installing the functional module	13			
7	Wiring	14			
	Safety instructions.....	14			
	Notes on wiring.....	14			
	Voltage supply for a limited number of modules.....	15			
	Polarity of the power supply.....	15			
	Strain relief.....	15			
	Terminal connections.....	15			
8	Commissioning the functional module ..	17			
	Description of functional objects.....	17			
	Network variables.....	18			

1 General

About this manual

This manual enables operating or service personnel to correctly install the product described below and to use it safely and efficiently.

Functional module LON-WA1/FT3

This manual is intended for use by fitting and installation companies, in-house technicians, technical staff, instructed persons, and qualified electricians or air conditioning technicians.

It is essential that these individuals read and fully understand this manual before starting any work. The basic prerequisite for safe working is to comply with the safety notes and all instructions in this manual.

The local regulations for health and safety at work and general safety regulations also apply.

This manual must be given to the system owner when handing over the system. The system owner must include the manual with the system documentation. The manual must be kept in a place that is accessible at all times.

Illustrations in this manual are mainly for information and may differ from the actual design.

Symbols used in this manual

Safety notes

Symbols are used in this manual to alert readers to areas of potential hazard. Signal words express the degree of the hazard.

Comply with all safety instructions and proceed carefully to avoid accidents, injuries and damage to property.

DANGER!

Imminently hazardous situation which, if not avoided, will result in death or serious injury.

WARNING!

Potentially hazardous situation which, if not avoided, may result in death or serious injury.

CAUTION!

Potentially hazardous situation which, if not avoided, may result in minor or moderate injury.

NOTICE!

Potentially hazardous situation which, if not avoided, may result in property damage.

ENVIRONMENT!

Environmental pollution hazard.



Tips and recommendations



Useful tips and recommendations as well as information for efficient and fault-free operation.





Specific safety notes

The following symbols are used in safety notes to alert you to specific hazards:

Warning signs	Type of danger
	Warning – high-voltage.
	Warning – danger zone.

Additional markers

In order to highlight instructions, results, lists, references and other elements, the following markers are used in this manual:

Marker	Explanation
 1., 2., 3. ...	Step-by-step instructions
	Results of actions
	References to sections in this manual and to other applicable documents
	Lists without a defined sequence
[Switch]	Operating elements (e.g. push buttons, switches), display elements (e.g. LEDs)
'Display'	Screen elements (e.g. buttons or menus)

Limitation of liability

The information in this manual has been compiled with reference to the applicable standards and guidelines, the state of the art, and our expertise and experience of many years.

The manufacturer does not accept any liability for damages resulting from:

- Non-compliance with this manual
- Incorrect use
- Operation or handling by untrained individuals
- Unauthorised modifications

The actual scope of delivery may differ from the information in this manual for special constructions, additional order options or as a result of recent technical changes.

Copyright

This document, including all illustrations, photos, etc., is protected by copyright.

Any use of this document without the written consent of the manufacturer is an infringement of copyright; this applies in particular to disclosing this document to third parties, to publishing, copying, microcopying, or translating content, and to saving content on electronic systems or modifying it.

Violators will be held liable for any damage. We reserve the right to make further claims.

Replacement parts

 **WARNING!**

Safety risk due to incorrect replacement parts

Incorrect or faulty replacement parts may affect the safety of people and cause damage to property or even total failure of the system.

If you intend to use a replacement part that has not been approved by TROX, make sure beforehand that it is safe to use.

Buy replacement parts from TROX or from an authorised supplier. See the address on page 2.

Defects liability

For details regarding defects liability please refer to Section VI, Warranty Claims, of the Delivery and Payment Terms of TROX GmbH. The Delivery and Payment Terms of TROX GmbH are available at www.troxtechnik.com.

Customer service

TROX Technical Service

To ensure that your request is processed as quickly as possible, please keep the following information ready:

- Product name
- TROX order number
- Delivery date
- Brief description of the fault

Online	www.troxtechnik.com
Phone	+49 2845 202-400

2 Security

Dangers and risks



DANGER!

Risk to life from incorrect wiring!

Incorrect wiring can lead to dangerous electrical voltages on the PCB of the functional module and at the actuator.

- Have work on the electrical system carried out only by skilled qualified electricians.
- Do not connect a 230 V supply voltage if the connected actuators are designed for 24 V.
- Do not connect a 230 V supply voltage if the wire links for 24 V have been set.



NOTICE!

Risk of damage to property due to large temperature differences

If any electronic components have been kept in an unheated area, condensation may form and damage the electronic components beyond repair.

- Before you start commissioning, make sure that all devices have warmed up to ambient temperature. Only after about 2 hours will the system have reached room temperature.



NOTICE!

Risk of damage to property due to electrostatic charge

Electrostatic charge can damage the electronics.

- Avoid skin contact with any components or printed circuits.
- Touch an equipotentially bonded metal surface before you touch any printed circuit boards.
- Wear conductive footwear and antistatic clothing.



NOTICE!

Risk of damage to property due to foreign matter and liquids!

Foreign matter and liquids that get into the unit may damage the electronic parts.

- Do not use any liquids for cleaning.
- Remove foreign matter, if any.
- If the device emits a smell or smoke, have it checked by the manufacturer.
- If liquid gets into the module, let the module completely dry before commissioning.



NOTICE!

Risk of damage to property!

Over tightening the fixing screws may damage the casing.

- Tighten the screws only hand-tight.

Correct use

Functional module LON-WA1/FT3 is used to monitor and control motorised fire dampers or smoke control dampers in LON networks. The module can be used for up to four fire dampers or smoke control dampers. The dampers then have to be fitted with a suitable 24 V or 230 VAC actuator (TROX or Belimo).

Incorrect use

Do not use the functional module for areas of application that are not described in this manual.

Do not use the functional module:

- outdoors
- in wet areas
- in areas with potentially explosive atmospheres

Residual risks

Failure of the LON interface does not affect the safety function of the fire dampers but does affect data exchange with the central BMS.

Smoke control dampers maintain the position that was last sent from the LON interface. Safety-related applications require further precautions.

Qualified staff



WARNING!

Danger of injury due to insufficiently qualified individuals!

Incorrect use may cause considerable injury or damage to property.

- Only skilled qualified personnel must carry out work.

The following degrees of qualification are required for the work described in the operating manual:

Skilled qualified electrician

Skilled qualified electricians are individuals who have sufficient professional or technical training, knowledge and actual experience to enable them to work on electrical systems, understand any potential hazards related to the work under consideration, and recognise and avoid any risks involved.

3 Transport and installation

Supply package

Check delivered items immediately after arrival for transport damage and completeness.

Properly dispose of packaging material.

Supply package

LON-WA1/FT3

Installation and commissioning manual

Transport

- If possible, take the functional module in its transport packaging up to the installation location.
- Do not remove the protective wrapping until just before installation.

Storage

For temporary storage please note:

- Leave the product in its packaging and do not expose it to the effects of weather.
- Store the product in a dry place and away from direct sunlight.
- Temperature -10 °C to $+70\text{ °C}$, humidity 90% max. (no condensation)

4 Structure and functional description

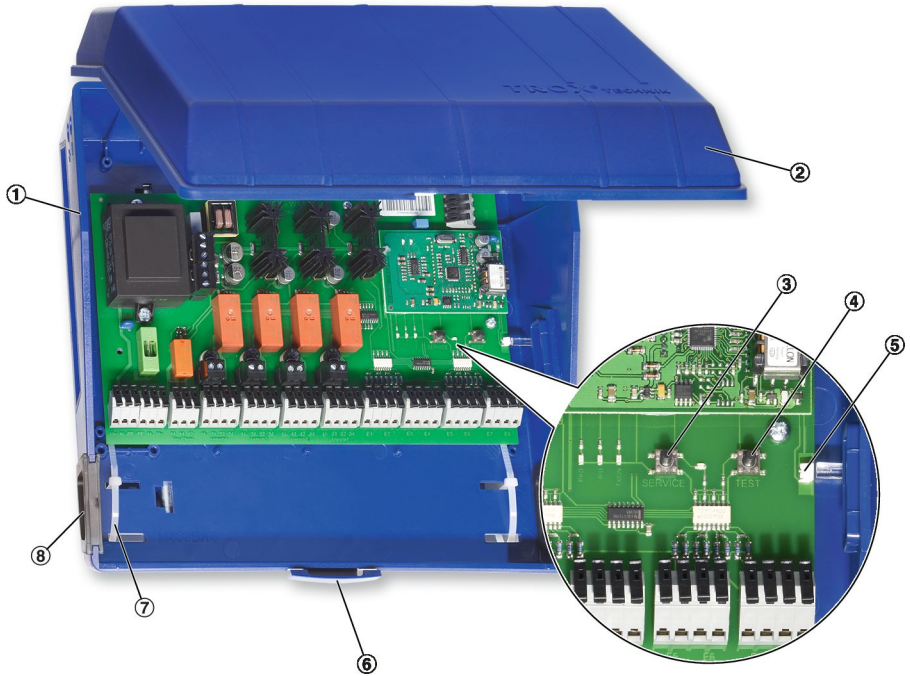

Fig. 1: Functional module LON-WA1/FT3

- | | | | |
|---|---|-------------|---|
| 1 | Casing | 6 | Cover lock |
| 2 | Cover | 7 | Strain relief (cable clips, both sides) |
| 3 | 'Service' push button | 8 | Cable entry points (both sides) |
| 4 | 'Test' push button | (not shown) | Rating plate |
| 5 | LED for heartbeat (illumination visible on the outside of the casing) | | |

Push buttons on the main PCB

Push button	Function
Test	Starts a functional test for the damper: The damper is moved from the 'Normal' position to the 'Fire' position and back to the 'Normal' position.
Service	Sends the neuron ID for system integration

Functional description

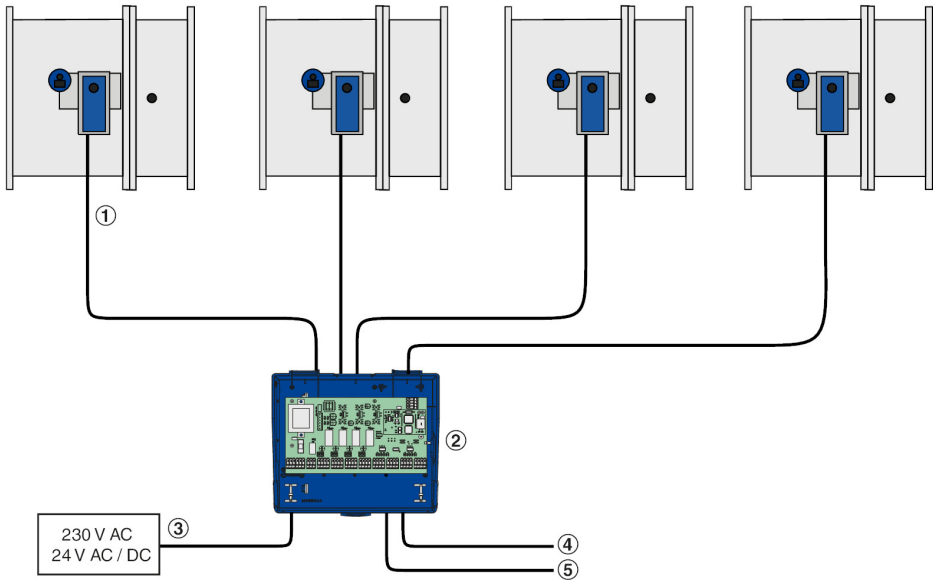

Fig. 2: Functional module LON-WA1/FT3 with 4 fire dampers

- | | | | |
|---|--|---|----------------------|
| 1 | Actuators for fire dampers or smoke control dampers (up to four) | 4 | LON FTT twisted pair |
| 2 | LON-WA1/FT3 | 5 | FireChain |
| 3 | Supply voltage, 230 V AC or 24 V AC/DC depending on the actuator voltage range | | |

Functional module LON-WA1/FT3 is used to monitor and control motorised fire dampers or smoke control dampers in LON networks. The module can be used for up to four fire dampers or smoke control dampers.

Safe positions

In case of an error, the following safe positions apply, based on VDMA sheet 24200-1 (Automated fire protection and smoke extract systems):

- | | |
|----------------------|-------------------------------|
| Fire damper | - Closed |
| Smoke control damper | - Last position is maintained |

Control input signal

Input variable `ActuDrive` is used to control the fire damper or smoke control damper.

Output variable `ActuPosn` is used to signal the current damper blade position.

- | | |
|--------|---|
| Normal | - Fire damper in OPEN position |
| Fire | - Fire damper in CLOSED position |
| Normal | - Smoke control damper in CLOSED position |
| Fire | - Smoke control damper in OPEN position |

When LON-WA1/FT3 is supplied with voltage, the connected dampers move to their respective normal position.

Monitoring function

If LON-WA1/FT3 is used as part of an overall fire protection system, the heartbeat function should be activated for safety reasons. Setting parameter `MaxRcvTime` for variable `ActuDrive`, and parameter `MaxSendTime` for variable `ActuPosn`, ensures that LON-WA1/FT3 regularly sends and receives information. This ensures that the transmission path is being monitored. In case of an error, the damper moves to a safe position, and an alarm is output.

Pulse

The `Pulse` variable is used to check a LON network. If the input variable is set, LON-WA1/FT3 will change the output variable after 1 second. If there is a chain of modules, a trigger pulse is generated which can be read out at the end of the chain after $N \times 1 \text{ s}$ (N = number of LON-WA1/FT3 modules).

Damper blade functional test

Input variable `FT_Test` or the `Test` push button on the module can be used to initiate a functional test of the damper. This moves the dampers to the `Fire` position (fire damper = `CLOSED` / smoke control damper = `OPEN`) and back to the `Normal` position

(fire damper = `OPEN` / smoke control damper = `CLOSED`). The output variable `FT_Test` indicates whether a test is being carried out. A test run that has been initiated remains active for the time defined with `TestHold-Time`. If `ActuDrive` switches to 'Fire' during a test, the test is automatically aborted.

FireChain

If there is a chain of modules (and hence fire dampers), the `FireChain` variables can transmit a signal from the first to the last but will not release a damper. The `FireChain` relay in the LON-WA1/FT3 module receives a signal that can be used for consolidated alarms or to switch off systems. This function is only available for fire dampers.

5 Technical data

Dimensions

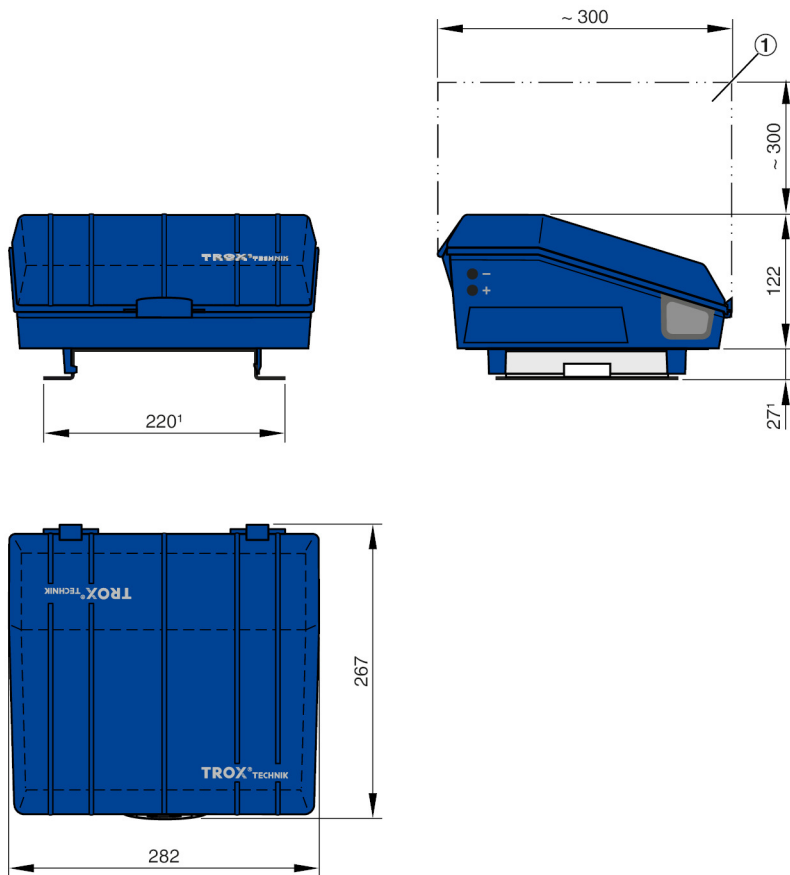

Fig. 3: Dimensions

Technical data

Supply voltage 230 V	230 Volt AC $\pm 10\%$, 50/60 Hz
Supply voltage 24 V	24 V AC or 24 V DC $\pm 10\%$
Power consumption without actuators	Approx. 12 VA without actuators (4.8 VA or W)
Max. switch rating for Damper 1 relay (24 V AC)	Max. switch rating 5 A with 24 V AC/DC
Max. switch rating for Damper 2 relay (24 V AC)	Max. switch rating 5 A with 24 V AC/DC
Max. switch rating for Damper 3 relay (24 V AC)	Max. switch rating 5 A with 24 V AC/DC

Max. switch rating for Damper 4 relay (24 V AC)	Max. switch rating 5 A with 24 V AC/DC
Max. switch rating for FireChain relay	Max. switch rating 5 A with 24 V AC/DC
LON interface	4 terminals, LON; FTT free topology
Operating temperature	+10 to +60 °C
Storage temperature	-10 to +70 °C
Relative humidity (no condensation)	20 to 95%, no condensation
IEC protection class with 230 V	II
IEC protection class with 24 V (extra low voltage)	III
Protection level	IP 20
Material	ABS plastic, blue (RAL 5002)
Software application	xif/apb-files under www.trox.de

Terminals

Supply voltage	2 × 3-pole for 0.08 – 2.5 mm ² Double terminals for looping through
Actuator control	4 x 4-pole spring-loaded terminals for 0.08 – 2.5 mm ²
Actuator end positions	4 x 4-pole spring-loaded terminals for 0.08 – 2.5 mm ²
LON network	4-pole spring-loaded terminals for 0.08 – 2.5 mm ² ; FT5000 free topology Double terminals for looping through
FireChain signal	3-pole for 0.08 – 2.5 mm ²

6 Installing the functional module

Installation

Retrofitting

If you retrofit a functional module for a fire damper, you can choose any installation location; in the event of a fire, the damper blade will be moved to its safe position (closed) even if the module fails. We recommend you to use the TROX universal mounting bracket for fixing the module to a wall, for example.

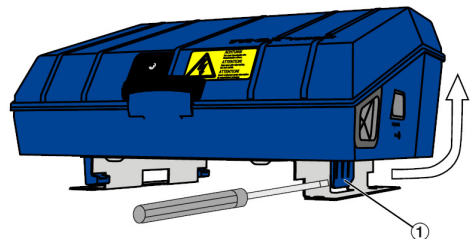

1. ▶ Detach LON-WA1/FT3 from the mounting bracket. To do so, use a screwdriver to flip up the lug (1), then lift the module up.

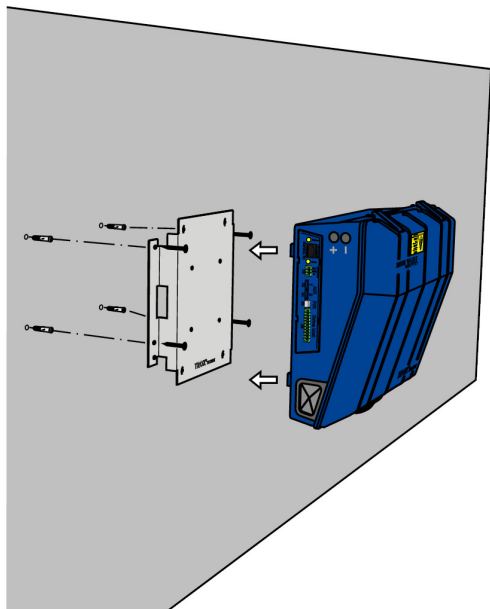

2. ▶ Use suitable screws $\varnothing 4$ mm to fix the mounting bracket to a wall or duct.

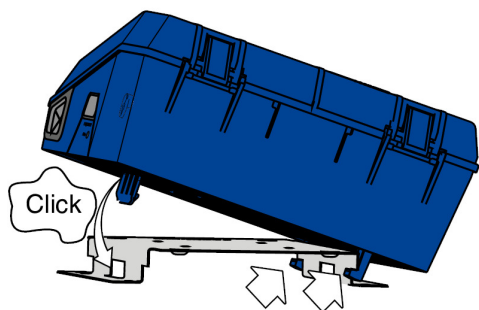

3. ▶ Press LON-WA1/FT3 as shown onto the mounting bracket until it clicks into place.

7 Wiring

Safety instructions

Personnel:

- Skilled qualified electrician



DANGER!

Danger of death due to electric current!

Danger of electric shock! Do not touch any live components!

- Switch off the supply voltage and secure it against being switched on accidentally before working on the unit.
- Ensure that no voltage is present.
- Work on the electrical system must only be carried out by skilled qualified electricians.

Notes on wiring

Use only cables that are designed for the supply voltage for which they will be used. The length and cross section as well as any contact resistance may increase voltage losses. The power rating of each unit must also be considered. A skilled qualified electrician has to select the correct cable types and sizes. This job must only be carried out by specialist electrical companies.

- For the electrical connection comply with any applicable regulations and follow the code of good practice. Be sure to comply with the applicable guidelines for working on electrical and electronic equipment as well as with any applicable local regulations.
- For electrical connection data refer to the 'Technical data' chapter.
- Protect any connections from physical damage.
- Feed cables through the cable entry points into the casing. Feeding the cable may be easier if you pull out the side parts of the casing.

Voltage supply for a limited number of modules

If the supply voltage is 24 V AC/DC, you must not connect more than two LON-WA1/FT3 modules with the double stack terminals as otherwise the load current on the PCB and the terminals will become too high.

Polarity of the power supply

Be sure to maintain the correct polarity when you wire up modules to a 24 V DC supply.

Strain relief

Use a wire clamping bracket or other type of strain relief for all cables. You may use the cable clips provided in the casing (Fig. 1/7).

Terminal connections

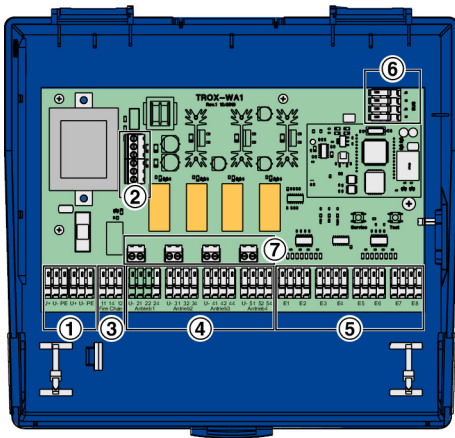

Fig. 4: LON-WA1/FT3

- 1 Connection for the supply voltage
- 2 Wire links to set the supply voltage
- 3 Connection for the FireChain relay
- 4 Connections for fire damper or smoke control damper actuators (up to four)
- 5 Connections for limit switches on fire damper or smoke control damper actuators
- 6 LON network
- 7 Output wire links (output is volt-free if no wire link is attached)

Connecting the supply voltage

Functional module LON-WA1/FT3 can be connected to a supply voltage of 230 V AC or 24 V AC/DC. Choose the supply voltage according to the actuators, then use two wire links to set the voltage on the functional module. You have to set the voltage on the terminal block (Fig. 4/2); refer to the tables below for the position of the wire links.



DANGER!

Risk to life from incorrect wiring!

Incorrect wiring can lead to dangerous electrical voltages on the PCB of the functional module and at the actuator.

- Do not connect a 230 V supply voltage if the connected actuators are designed for 24 V.
- Do not connect a 230 V supply voltage if the wire links for 24 V have been set.

230 V AC (Fig. 4/1)

Terminal	Used for	Position of wire links (Fig. 4/2)
U+	L	
U-	N	
PE	PE	

24 V AC / DC (Fig. 4/1)

Terminal	Used for		Position of wire links (Fig. 4/2)
	24 AC	24 DC	
U+	L	+24 V	
U-	N	0 V	
PE	PE	–	

Connection of the FireChain relay (Fig. 4/3)

Terminal	Description
11	The relay can be used to switch off a ventilation system, for example.
14	
12	

Connection of actuators (Fig. 4/4)

Terminal	Description
U- 24	Output, control signal to the actuator of fire damper 1 or smoke control damper 1
U- 34	Output, control signal to the actuator of fire damper 2 or smoke control damper 2
U- 44	Output, control signal to the actuator of fire damper 3 or smoke control damper 3
U- 54	Output, control signal to the actuator of fire damper 4 or smoke control damper 4

If no wire links are set (Fig. 4/7), the outputs are volt-free; common contact (21, 31, 41, 51) = U+

Connection of limit switches (Fig. 4/5)

Limit switches	Terminal Actuator	Terminal LON-WA1/FT3	Damper blade position
Actuator 1	S4+S6	E1	OPEN
	S1+S2	E2	CLOSED
Actuator 2	S4+S6	E3	OPEN
	S1+S2	E4	CLOSED
Actuator 3	S4+S6	E5	OPEN
	S1+S2	E6	CLOSED
Actuator 4	S4+S6	E7	OPEN
	S1+S2	E8	CLOSED

Terminals for damper blade position OPEN (E3, E5, E7) that are not used must have a wire link; this applies, for example, if you connect only two dampers. Otherwise an alarm message will be output.

Connection of the LON network (Fig. 4/6)

Terminal	Connection
NA	LON-A
NB	LON-B
NA	LON-A
NB	LON-B

Connection of data cables

LON-WA1/FT3 has terminals for two LON data bus cables.

- Strip the insulation from the bus cable (at least two wires), insert the bare wires into the terminals and tighten the screws by hand.
- Make sure that the polarity of the conductor pairs is correct. Incorrect polarity will result in inverted data signals and hence communication errors.
- Support the bus cables with a wire clamping bracket or other strain relief (by others).
- A maximum of 32 units can be operated on one network segment.
- To avoid cable reflections, network segments must be terminated at both ends with 120 Ω bus terminal resistors.

8 Commissioning the functional module

Before commissioning, the functional module has to be configured with the LonMaker® plug-in and according to the following specifications

↳ 8.2 'Configuration with the LonMaker® plug-in' on page 23.

Commissioning of the functional module in conjunction with a fire damper is to be performed by the system installer as part of commissioning of the overall fire protection system.

Description of functional objects

The specification of the node is based on LonMark profile 11001, Fire Smoke Damper Actuator (FSDA), and has been extended to cover the special functions of the functional module.

The LON node consists of the node object and four FSDA objects. The FSDA objects consist of network variables and configuration parameters. All variables and parameters are based on standard network variables (SNVT) to facilitate the integration of LON-WA1/FT3 with a LonWorks network.

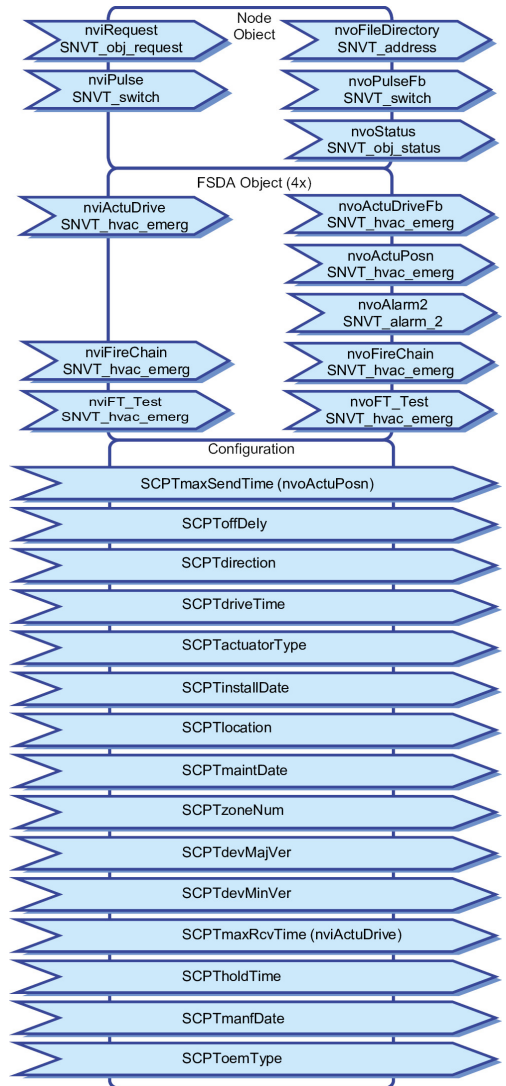

Fig. 5: LON functional objects

Network variables

Node object

nviRequest

SNVT type: SNVT_obj_request

Function: Variable *nviRequest* is used to request information and to have the node perform certain actions. The following parameters can be received:

Parameter	Function
RQ_Normal	Initialise node, reset status
RQ_Disabled	Disabled
RQ_Update_Status	Request status, respond via <i>nvoStatus</i>
RQ_Update_Alarm	Disabled
RQ_Report_Mask	List of all status bits
RQ_Enable	Disabled
RQ_Clear_Alarm	Disabled
RQ_Self_Test	Self test of the node

nviPulse

SNVT type: SNVT_switch

Function: *nviPulse* is used to check a LON network. If input variable *nviPulse* = 1, LON-WA1/FT3 will after 1 second change output variable *nvoPulse* from 0 to 1. If output variable *nvoPulse* and input variable *nviPulse* of the next module form a chain, a trigger pulse is generated which can be read out at the end of the chain after N x 1 second. (N = number of LON-WA1/FT3 modules).

Valid values:

Value	Function
1	Pulse signal
0	No pulse signal

nvoFileDirectory

SNVT type: SNVT_address

Function: Start address to access the file system with the configuration variables listed below.

nvoPulseFB

SNVT type: SNVT_switch

Function: See *nviPulse*.

nvoStatus

SNVT type: SNVT_obj_request

Function: Output variable *nvoStatus* contains the response to a previous request by *nviRequest* with the requested status bits:

Status bits	Function
invalid_id	Invalid object ID requested or ID not available
invalid_request	Invalid parameter
disabled	Node without a function (not active)
comm_failure	Communication failure
fail_self_test	Self test has failed
self_test_in_progress	Self test in progress

FSDA object

nviActuDrive

SNVT type: SNVT_hvac_emerg

Function: Input variable used to control the damper blade position. The input variable can be addressed in intervals; the number of repeats must be defined with *SCPTmaxRcvTime*.

Valid values:

Value	Function
EMERG_NORMAL	Normal position
EMERG_FIRE	Fire position
EMERG_NUL	Normal position

nviFireChain

SNVT type: SNVT_hvac_emerg

Function: If there is a chain of modules (and hence fire dampers), the *nviFireChain* and *nvoFireChain* variables can transmit a signal from the first to the last, but will not release a damper. In the event of a fire, i.e. when *nviFireChain* or *nviActuPosn* changes to FIRE, the chain relay contact opens. This effect can be used, for example, to switch off a ventilation system.

Valid values:

Value	Function
EMERG_NORMAL	Normal position
EMERG_FIRE	Fire position

nviFT_Test

SNVT type: SNVT_hvac_emerg

Function: Input variable used to initiate a functional test of the damper. The damper is then moved to the Fire position. The damper remains in the 'Fire' position for the time set with configuration parameter *SCPTholdTime*. The damper can then be moved back to its Normal position using variable *nviActuDrive*.

Valid values:

Value	Function
EMERG_NORMAL	No test
EMERG_FIRE	Test

nvoActuDriveFb

SNVT type: SNVT_hvac_emerg

Function: Output variable that shows the status of *nviActuDrive*.

Valid values:

Value	Function
EMERG_NORMAL	Normal position
EMERG_FIRE	Fire position
EMERG_NUL	Normal position

nvoActuPosn

SNVT type: SNVT_hvac_emerg

Function: Output variable that reflects the current damper blade position. If the position changes, the values are immediately reflected. Changes can also be transmitted in intervals; in this case the repeat intervals must be set using *SCPmaxSendTime*.

Valid values:

Value	Function
EMERG_NORMAL	Normal position
EMERG_FIRE	Fire position
EMERG_NUL	Zero position (between Normal and Fire)

nvoAlarm2

SNVT type: SNVT_alarm2

Function: Alarm output used to signal an incorrect function of the LON node to a monitoring system. The message includes detailed information on the incorrect function. A message is issued as soon as an error occurs.

Alarm type	Description	Priority level	Explanation
AL_NO_COND	Normal	16	Damper blade is in Normal position.
AL_FIR_TRBL	Fire	4	Damper blade is in Fire position; this alarm type is also output during a test run.
AL_FIR_MONITOR_COND	TimeToNormal Position	6	The damper blade has required more time than the 'DriveTime' set in the 'Config' window in order to move from the Fire position to the Normal position.
	TimeToFire Position	6	The damper blade has required more time than the 'OffTime' set in the 'Config' window in order to move from the Normal position back to the Fire position.
AL_ERROR	ReceiveUpdate Error	6	The input variable nviActuDrive has not been updated within the 'MaxRcvTime' set in the 'Config' window.
	LimitSwitchFault	6	The damper has signalled that it is in Normal position and in Fire position at the same time.

nvoFireChain

SNVT type: SNVT_hvac_emerg

Function: See *nviFireChain*.

nvoFT_Test

SNVT type: SNVT_hvac_emerg

Function: Output variable used to check whether a damper test is required. Valid values are the same as for *nviFT_Test*.

Configuration parameters

SCPTmaxSendTime

SCPT type: SCPTmaxSendTime

Function: Used to define the interval [seconds] for forwarding output variable *nvoActuPosn*. If you enter 0 seconds, the function will be switched off.

SCPToffDely

SCPT type: SCPToffDely

Function: Used to define the maximum time for a damper blade to move to the Fire position. If this time is exceeded, alarm type *AL_FIR_MONITOR_COND* will be output. If you enter 0 seconds, the running time will not be checked. (Note this when you use the module for non-motorised dampers.)

SCPTdirection

SCPT type: SCPTdirection

Function: Used to define the direction of movement of the damper blade (which depends on the type of damper).

Valid values:

Value	Function
0	Fire damper
1	Smoke control damper

Standard value: 0

SCPTdriveTime

SCPT type: SCPTdriveTime

Function: Used to define the maximum time for a damper blade to move to the Normal position. If this time is exceeded, the alarm type

`AL_FIR_MONITOR_COND` will be output, and the damper blade moves back to the Fire position. If you enter 0 seconds, the running time will not be checked. (Note this when you use the module for non-motorised dampers.)

SCPTactuatorType

SCPT type: SCPTactuatorType

Function: Used to describe the connected damper with up to 30 ASCII characters.

SCPTinstallDate

SCPT type: SCPTinstallDate

Function: Used to define the date and time when the node was installed in the LON network.

SCPTlocation

SCPT type: SCPTlocation

Function: Used to describe the physical location of the LON module with up to 30 ASCII characters.

SCPTmaintDate

SCPT type: SCPTmaintDate

Function: Used to define date and time when the damper and actuator were last maintained or inspected.

SCPTzoneNum

SCPT type: SCPTzoneNum

Function: Used to define a zone number that may help to indicate the location of the LON module.

SCPTdevMajVer

SCPT type: SCPTdevMajVer

Function: Displays the version of the LON-WA1/FT3 software (x,...).

SCPTdevMinVer

SCPT type: SCPTdevMinVer

Function: Displays the subversion (minor version) of the LON-WA1/FT3 software (...x).

SCPTmaxRcvTime

SCPT type: SCPTmaxRcvTime

Function: Used to define the period of time [seconds] within which a signal must be forwarded to the `nviActuDrive` input. If the input is not updated accordingly, the damper blade moves to the Fire position and alarm type `AL_ERROR` will be output. If you enter 0 seconds, no check will be carried out.

SCPTholdTime

SCPT type: SCPTholdTime

Function: Used to define for how long [seconds] a test run that has been initiated using variable `nviFT_Test` shall remain active before the damper blade is moved back to the Normal position by variable `nviActuDrive`.

SCPTmanfDate

SCPT type: SCPTmanfDate

Function: Displays the creation date ('manufacturing date') of the LON-WA1/FT3 software (cannot be changed).

SCPToemType

SCPT type: SCPToemType

Function: Displays the OEM type (cannot be changed).

Configuration with the LonMaker® plug-in

The TROX LON-WA1B3_01 plug-in is an LNS-enabled plug-in; it is based on the standard of the network management tool LonMaker® 3 for Windows.

Installing the plug-in

Before you install the plug-in on your PC:

- Check the system requirements
- Install LonMaker® 3 on your PC
- Install the Device Resource Files (DRF)

Device Resource Files (DRF)

The Device Resource Files contain the definitions of the various network variable types. The application for LON-WA1/FT3 uses only standard network variables (SNVTs); this means that no manufacturer-specific definitions are required.

However, the latest version of the Device Resource Files (version 13.0 or higher) from LONMARK® should be installed on your computer, see <http://www.lonmark.org>

Installation

Start 'Setup.exe'.

Follow the prompts to install the software; you should not change the default path and directory.

A new TROX LNS PlugIn group of applications will be installed under Start/Programs (Windows).

Starting the plug-in

LON-WA1/FT3 configuration requirements:

- The functional module has been correctly installed, integrated with the LON network, and is working.
- The LonMaker software, the Device Resource Files and the plug-in have been correctly installed on your PC.

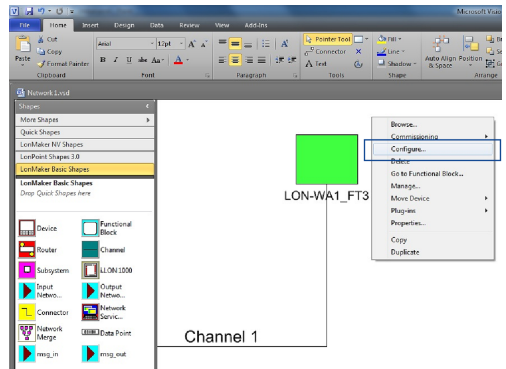

Fig. 6: Configure

- ▶ Use the LonMaker® network management tool to start the plug-in for a device. To do so, select the 'node', then click right and select 'Configure'.

The plug-in is started for each new LON node, i.e. the plug-in is used to access each node. Do not open more than one plug-in at a time.

Configuring the module

'Main' window

The TROX LON-WA1B3_01 plug-in includes windows that can be selected using tabs. Use each window to enter data for a functional module or to see current values.

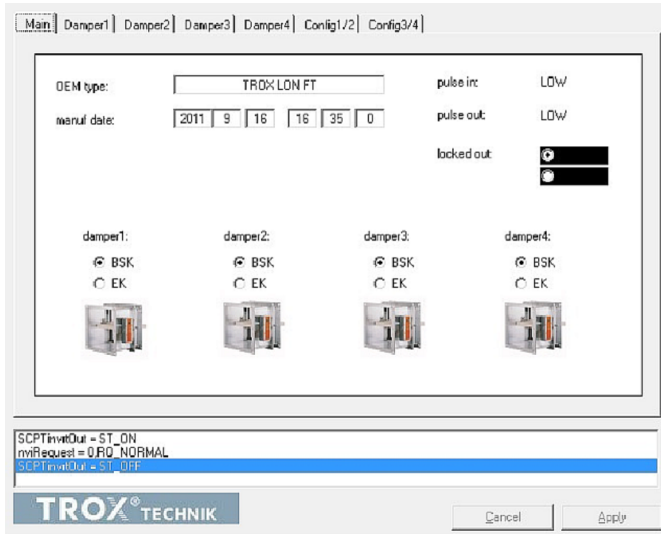

Fig. 7: 'Main' window

Use the 'Main' window to see general information and to make basic settings:

OEM type - Displays the OEM type.

Manuf Date - Displays the software release date ('manufacturing date'): YYYY, MM, DD, HH, MM, SS.

Pulse In/Out - Used to check the LON network: 'Low' = 0, 'High' = 1

Locked Out - Used to activate or deactivate the error memory in LON-WA1/FT3.

Damper1...4 - Used to select the type of damper

'BSK' = fire damper

'EK' = smoke control damper

Damper1...4 window

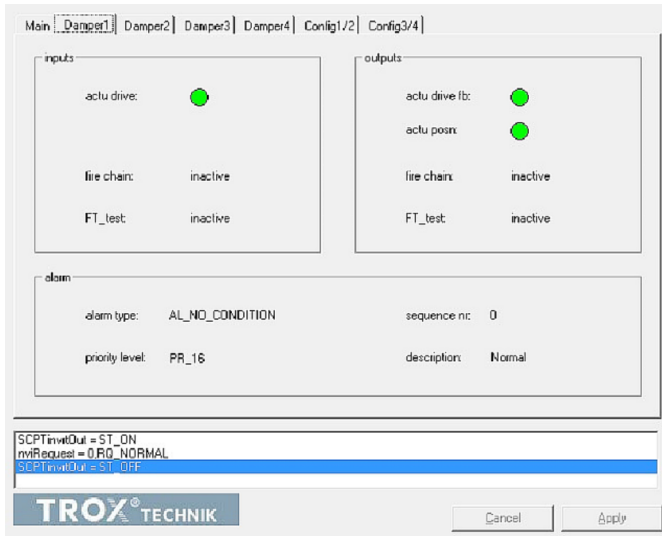

Fig. 8: 'Damper1' window

The 'Damper' windows show the input and output variables as well as the alarm status for the respective fire damper or smoke control damper.

Inputs

ActuDrive: LED that shows the status of input variable *nviActuDrive* ↪ 'nviActuDrive' on page 18

Colour	Meaning
Red	'Move damper blade to the Fire position' command
Green	'Move damper blade to the Normal position' command
Yellow	'Move damper blade to the Normal position' command
Grey	LON-WA1/FT3 offline

FireChain: Shows the status of input variable *nviFireChain*, ↪ 'nviFireChain' on page 19.

Value	Meaning
active	FireChain relay is open
inactive	FireChain relay is closed

FT_Test: Shows the status of input variable *nviFT_Test* ↪ 'nviFT_Test' on page 19

Value	Meaning
active	Damper functional test is running
inactive	No test

Actuating the 'Test' push button on LON-WA1/FT3 does not affect this input ('inactive' will be displayed).

Outputs

ActuDriveFb: Status of output variable *nvoActuDriveFb* ↪ '*nvoActuDriveFb*' on page 19; *ActuDriveFb* outputs the status of input variable *ActuDrive*.

Colour	Meaning
Red	Damper blade in Fire position
Green	Damper blade in Normal position
Yellow	Damper blade in Zero position (between Normal and Fire)
Grey	LON-WA1/FT3 offline

ActuPosn: Status of output variable *nvoActuPosn* ↪ '*nvoActuPosn*' on page 19; *ActuPosn* outputs the status of the limit switches on the damper.

Colour	Meaning
Red	Fire position
Green	Normal position
Yellow	Zero position (between Normal and Fire)
Grey	LON-WA1/FT3 offline

FireChain: Shows the status of output variable *nvoFireChain*, ↪ '*nviFireChain*' on page 19.

Value	Meaning
active	FireChain relay is open
inactive	FireChain relay is closed

FT_Test: Status of output variable *nvoFT_Test* ↪ '*nviFT_Test*' on page 19.

nvoFT_Test indicates that a test has been initiated, either using input *FT_Test* or using the test push button on LON-WA1/FT3.

Value	Meaning
active	Damper functional test is running
inactive	No test

Alarm

Shows the status of output variable *nvoAlarm2* ↗ '*nvoAlarm2*' on page 20.

Alarm type	Description	Priority level	Explanation
AL_NO_COND	Normal	16	Damper blade is in Normal position.
AL_FIR_TRBL	Fire	4	Damper blade is in Fire position; this alarm type is also output during a test run.
AL_FIR_MONITOR_COND	TimeToNormal Position	6	The damper blade has required more time than the ' <i>DriveTime</i> ' set in the ' <i>Config</i> ' window in order to move from the Fire position to the Normal position.
	TimeToFire Position	6	The damper blade has required more time than the ' <i>OffTime</i> ' set in the ' <i>Config</i> ' window in order to move from the Normal position back to the Fire position.
AL_ERROR	ReceiveUpdate Error	6	Input variable <i>nviActuDrive</i> has not been updated within the ' <i>MaxRcvTime</i> ' set in the ' <i>Config</i> ' window.
	LimitSwitchFault	6	The damper has signalled that the damper blade is in Normal position and in Fire position at the same time.

Priority level - Shows the priority of the alarm.

SequenceNo - Total number of alarm messages LON-WA1/FT3 emitted since start/reset. This serves as an alarm history to check whether alarms have been signalled correctly.

Description - Description of the alarm.

Config 1/2 and 3/4 windows

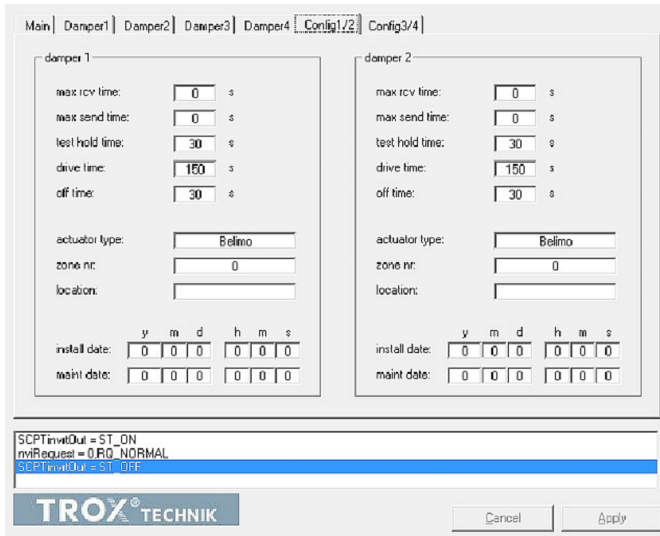

Fig. 9: 'Config' window

Use the 'Config' window to set configuration parameters for Damper1 to Damper4:

MaxRcvTime [seconds]: ↪ 'SCPTmaxRcvTime' on page 21

MaxSendTime [seconds]: ↪ 'SCPTmaxSendTime' on page 20

TestHoldTime [seconds]: ↪ 'SCPTHoldTime' on page 21

DriveTime [seconds]: ↪ 'SCPTdriveTime' on page 21

OffTime [seconds]: ↪ 'SCPToffDely' on page 20

ActuatorType: ↪ 'SCPTactuatorType' on page 21

ZoneNr: ↪ 'SCPTzoneNum' on page 21

Location: ↪ 'SCPTlocation' on page 21

InstallDate: ↪ 'SCPTinstallDate' on page 21

MaintDate: ↪ 'SCPTmaintDate' on page 21

9 Removal and disposal

Removal

If the device is no longer used, it has to be removed and disposed of in an environmentally friendly manner.

1. ▶ Remove the mains cable.
2. ▶ Remove any other cables.

Disposal

If no return or disposal agreement is in place, any disassembled components should be recycled:

- ▶ Have electronic waste and electronic components disposed of by an approved specialist disposal company.

10 Index**A**

Alarms..... 20, 27

C

Configuration..... 23

Configuration parameters

SCPTactuatorType..... 21

SCPTdevMajVer..... 21

SCPTdevMinVer..... 21

SCPTdirection..... 21

SCPTdriveTime..... 21

SCPTholdTime..... 21

SCPTinstallDate..... 21

SCPTlocation..... 21

SCPTmaintDate..... 21

SCPTmanfDate..... 22

SCPTmaxRcvTime..... 21

SCPTmaxSendTime..... 20

SCPToemType..... 22

SCPToffDely..... 20

SCPTzoneNum..... 21

Connection

Actuators..... 15

FireChain relay..... 15

LON network 16

Supply voltage..... 15

Control elements

Push button..... 9

Copyright..... 5

Correct use..... 7

D

Defects liability..... 5

Disposal..... 29

E

Electrical connection..... 15

Electrical installation..... 14

F

Function..... 10

G

General..... 4

H

Hotline..... 6

I

Incorrect use..... 7

Installation..... 13

L

LonMaker®..... 23

N

Network variable

nviActuDrive..... 18

nviFireChain..... 19

nviFT_Test..... 19

nviPulse..... 18

nviRequest..... 18

nvoActuDriveFb..... 19

nvoActuPosn..... 19

nvoAlarm2..... 20

nvoFileDirecotry..... 18

nvoFireChain..... 20

nvoFT_Test..... 20

nvoPulseFB..... 18

nvoStatus..... 18

P

Plug-in..... 23

'Config' window..... 28

'Main' window..... 24

Damper1...4 window..... 25

Installation..... 23

Start..... 23

R

Removal..... 29

Replacement parts..... 5

S		T	
Security.....	6	Technical data.....	12
Service.....	6	Technical Service.....	6
Software.....	23	Terminal connections.....	15
Staff.....	7	Transport.....	8
Storage.....	8	W	
Supply package.....	8	Wiring.....	15
Symbols.....	4		

