

Ceiling swirl diffusers

Type TDV-SilentAIR



Horizontal swirling air discharge



Horizontal one-way air discharge



Horizontal two-way air discharge



White air control blades

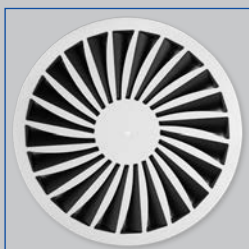

Circular diffuser face

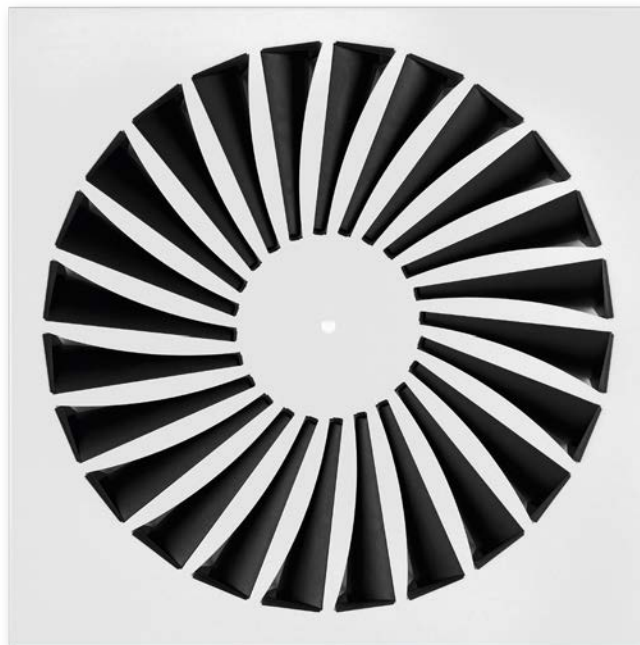

With very low sound power level for comfort zones and individually manually adjustable air control blades

Circular and square ceiling swirl diffusers

- Nominal sizes 300, 400, 500, 600, 625
- Volume flow rate range 11 – 315 l/s or 40 – 1134 m³/h
- Diffuser face made of galvanised sheet steel, powder-coated
- For supply and extract air
- For variable and constant volume flows
- For all types of ceiling systems, and with an extended border also suitable for freely suspended installation
- High induction results in a rapid reduction of the temperature difference and airflow velocity
- Air control blades can be adjusted individually for adjusting the air pattern
- Ideal for comfort zones

Optional equipment and accessories

- Exposed diffuser face available in RAL CLASSIC colours, air control blades in black or white
- Horizontal or vertical duct connection
- Plenum box with cord-operated damper blade and pressure tap

Type		Page
TDV-SilentAIR	General information	TDV – 2
	Function	TDV – 4
	Technical data	TDV – 7
	Quick sizing	TDV – 8
	Specification text	TDV – 10
	Order code	TDV – 11
	Variants	TDV – 12
	Dimensions and weight	TDV – 14
	Product details	TDV – 17
	Installation examples	TDV – 18
	Installation details	TDV – 19
	Commissioning	TDV – 22
	Basic information and nomenclature	TDV – 24

Application

Application

- Type TDV-SilentAIR ceiling swirl diffusers are used as supply air or extract air diffusers for comfort zones
- Attractive design element for building owners and architects with demanding aesthetic requirements
- Horizontal swirling supply air discharge for mixed flow ventilation
- The efficient swirl creates high induction levels, thereby rapidly reducing the temperature difference and airflow velocity (supply air variant)
- Individually adjustable air control blades to meet individual requirements
- For variable and constant volume flows
- For supply air to room air temperature differences from –12 to +10 K
- For room heights up to 4 m (lower edge of suspended ceiling)
- For all types of ceiling systems
- With an extended border also suitable for freely suspended installation (supply air variant)

Special characteristics

- Very low sound power level, ideal for comfort zones
- Individually manually adjustable air control blades
- For all types of ceiling systems, and with an extended border also suitable for freely suspended installation
- Black or white air control blades

Nominal sizes

- 300, 400, 500, 600, 625

Description

Variants

- TDV-SA-Q: Square diffuser face
- TDV-SA-R: Circular diffuser face
- TDV-SA-*-Z: Supply air
- TDV-SA-*-A: Extract air

Connection

- H: Horizontal duct connection
- V: Vertical duct connection

Parts and characteristics

- Circular or square diffuser face
- Diffuser face with individually manually adjustable air control blades
- Simple installation of the diffuser face due to central fixing screw with decorative cap
- Damper blade for volume flow rate balancing (optional)

Attachments

- M: Damper blade for volume flow rate balancing
- MN: Pressure tap and cord-operated damper blade for volume flow rate balancing with the diffuser face in place

Accessories

- Lip seal

Construction features

- Spigot suitable for circular ducts to EN 1506 or EN 13180
- Spigot with groove for lip seal (if accessory lip seal has been ordered)

Materials and surfaces

- Diffuser face made of galvanised sheet steel
- V, H: Plenum box and cross bar made of galvanised sheet steel
- X: Plenum box made of plastic and galvanised sheet steel
- Air control blades made of plastic, UL 94, V-0, flame retardant
- Lip seal made of rubber
- Exposed diffuser face powder-coated RAL 9010, pure white
- P1: Powder-coated, RAL CLASSIC colour
- Air control blades for supply air similar to RAL 9005, black; extract air variant without air control blades
- Q11: Air control blades for extract air similar to RAL 9005, black

- Q21: Air control blades for supply air and extract air similar to RAL 9010, white

Standards and guidelines

- Sound power level of the air-regenerated noise measured according to EN ISO 5135

Maintenance

- Maintenance-free as construction and materials are not subject to wear
- Inspection and cleaning to VDI 6022

Functional description

Ceiling swirl diffusers in air conditioning systems create a swirl to supply air to rooms. The resulting airflow induces high levels of room air, thereby rapidly reducing the airflow velocity and the temperature difference between supply air and room air. Ceiling swirl diffusers allow for large volume flow rates. The result is a mixed flow ventilation in comfort zones, with good overall room ventilation, creating only very little turbulence in the occupied zone.

Type TDV ceiling swirl diffusers have adjustable air control blades. The air pattern can be adjusted to meet different local requirements. Horizontal air

discharge is one-way, two-way or omni directional. Vertical air discharge is possible but only for heating. The supply air to room air temperature difference may range from -12 to $+10$ K.

A damper blade (optional) simplifies volume flow rate balancing for commissioning. Pressure tap and cord-operated damper blade (optional) allow for volume flow rate balancing with the diffuser face in place.

To give rooms an aesthetic, uniform look, Type TDV diffusers may also be used for extract air. Air control blades are not required for extract air applications.

Schematic illustration of the TDV-SA, with plenum box for horizontal duct connection

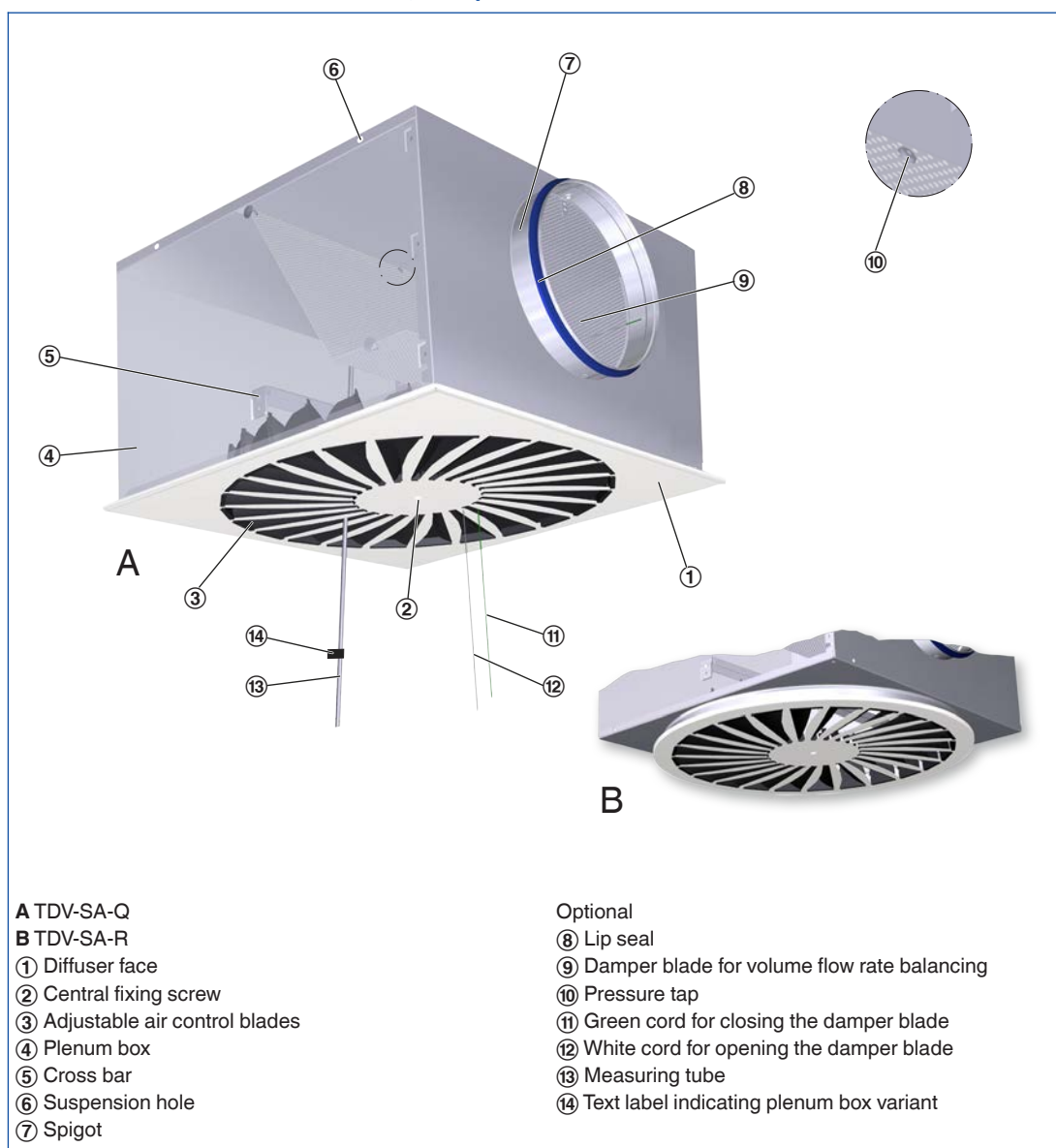

Air patterns

Air control blades set to external swirl

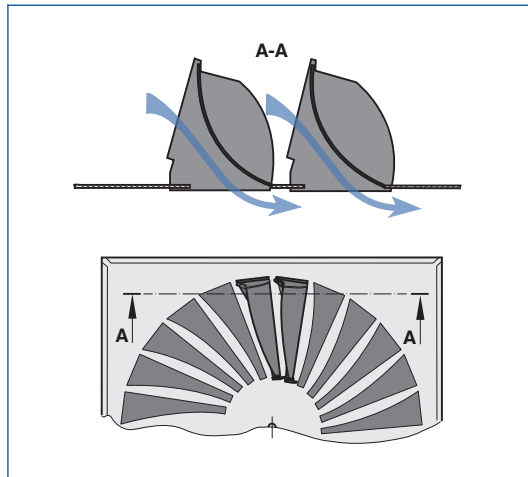

Air control blades set to internal swirl

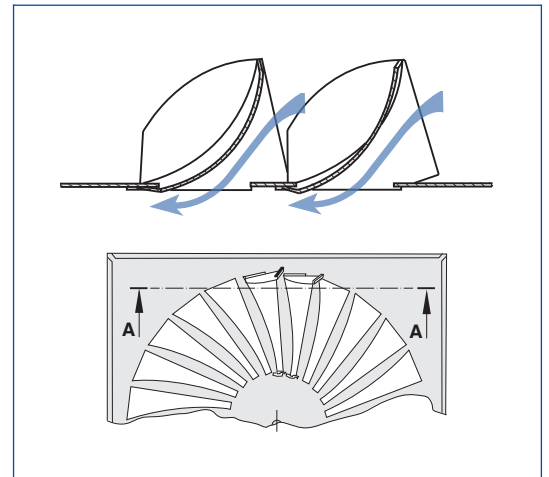

Horizontal air discharge

Horizontal omni directional air discharge

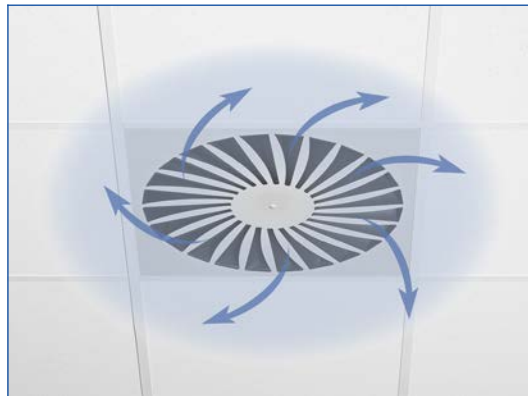

Setting of the air control blades

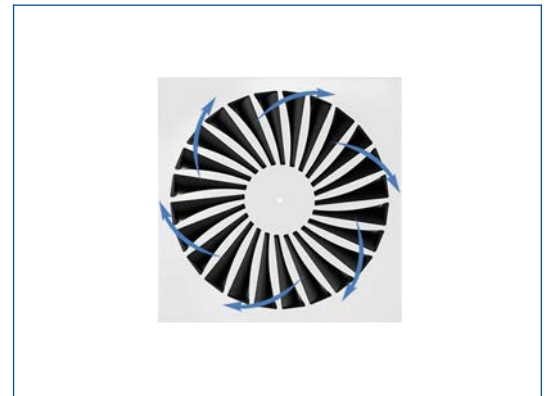

All air control blades set to external swirl

Setting of the air control blades

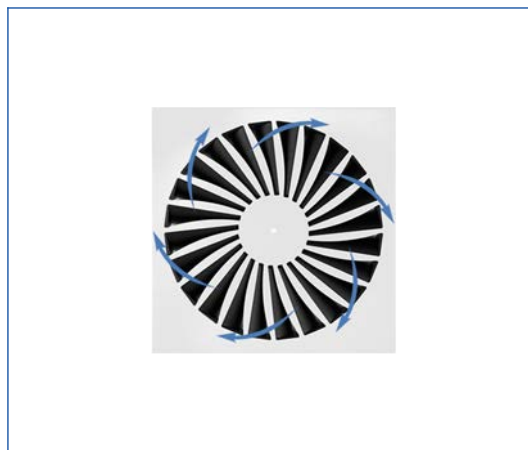

All air control blades set to external swirl

Air control blades set to internal swirl

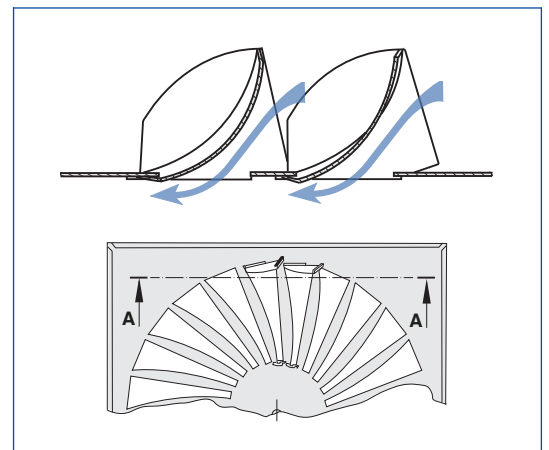

Horizontal two-way air discharge



Setting of the air control blades



Air control blades set to internal and external swirl per quadrant

Vertical air discharge

Air control blades set to vertical air discharge

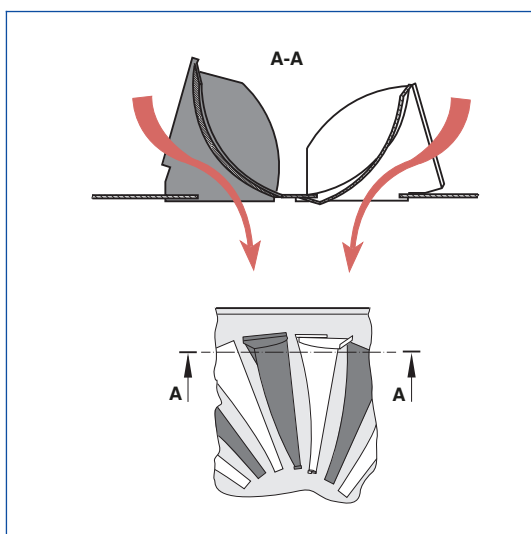

Vertical air discharge

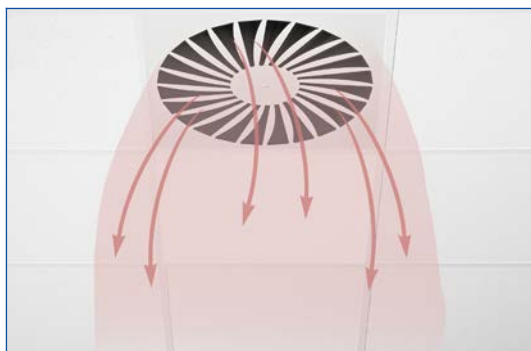

Setting of the air control blades



Air control blades set alternately to internal and external swirl

Nominal sizes	300, 400, 500, 600, 625 mm
Minimum volume flow rate, with $\Delta t_z = -6 \text{ K}$	11 – 47 l/s or 40 – 169 m ³ /h
Maximum volume flow rate, with $L_{WA} \cong 50 \text{ dB(A)}$	95 – 315 l/s or 342 – 1134 m ³ /h
Supply air to room air temperature difference	-12 to +10 K

Quick sizing tables provide a good overview of the volume flow rates and corresponding sound power levels and differential pressures.

The minimum volume flow rates apply to a supply air to room air temperature difference of -6 K .

The maximum volume flow rates apply to a sound power level of approx. 50 dB (A) with damper blade position 0° .

Exact values for all parameters can be determined with our Easy Product Finder design programme.

TDV-SA-Q-Z-H (supply air), sound power level and total differential pressure

Nominal size	\dot{V} l/s	\dot{V} m ³ /h	Damper blade position					
			0°		45°		90°	
			Δp_t Pa	L_{WA} dB(A)	Δp_t Pa	L_{WA} dB(A)	Δp_t Pa	L_{WA} dB(A)
300	11	40	1	<15	1	<15	2	<15
	40	144	11	25	14	27	32	25
	65	234	28	37	37	37	83	38
	95	342	60	50	79	48	179	52
400	20	72	1	<15	1	<15	3	<15
	60	216	10	26	12	18	28	27
	100	360	26	39	35	36	79	39
	140	504	52	50	68	49	154	49
500	30	108	1	<15	2	<15	6	<15
	80	288	11	22	16	21	46	26
	135	486	30	38	46	38	130	43
	190	684	59	50	91	51	257	55
600, 625	47	169	2	<15	2	<15	6	<15
	125	450	12	22	15	22	44	27
	200	720	30	38	39	37	112	43
	275	990	57	50	74	49	212	55

TDV-SA-R-Z-H (supply air), sound power level and total differential pressure

Nominal size	\dot{V} l/s	\dot{V} m ³ /h	Damper blade position					
			0°		45°		90°	
			Δp_t Pa	L_{WA} dB(A)	Δp_t Pa	L_{WA} dB(A)	Δp_t Pa	L_{WA} dB(A)
300	11	40	1	<15	1	<15	2	<15
	40	144	10	25	14	24	32	23
	70	252	31	35	43	36	97	38
	111	398	78	50	108	50	243	54
400	20	72	1	<15	1	<15	3	<15
	65	234	11	25	14	25	34	25
	115	414	34	39	45	39	105	41
	155	558	62	50	82	48	191	51
500	30	108	1	<15	2	<15	6	<15
	90	324	13	22	20	23	56	28
	155	558	39	38	59	40	165	45
	215	774	75	50	114	52	318	57
600, 625	47	169	2	<15	2	<15	6	<15
	130	468	13	21	19	22	47	30
	215	774	35	37	51	38	130	45
	295	1062	66	50	96	50	244	57

TDV-SA-*-Z-V (supply air), sound power level and total differential pressure

Nominal size	\dot{V}	\dot{V}	Damper blade position					
			0°		45°		90°	
	Δp_t	L_{WA}	Δp_t	L_{WA}	Δp_t	L_{WA}		
	l/s	m ³ /h	Pa	dB(A)	Pa	dB(A)	Pa	dB(A)
300	11	40	1	<15	1	<15	2	<15
	30	108	6	17	8	19	17	18
	65	234	29	37	36	38	82	38
	95	342	63	50	77	51	174	52
400	20	72	1	<15	1	<15	3	<15
	60	216	9	21	12	23	29	22
	110	396	31	39	40	39	96	42
	150	540	58	50	73	51	179	54
500	30	108	1	<15	2	<15	6	<15
	85	306	11	20	18	23	49	29
	140	504	30	38	49	42	133	46
	195	702	59	50	94	56	258	58
600, 625	47	169	2	<15	3	<15	7	<15
	120	432	12	23	17	25	42	33
	190	684	29	38	42	42	106	48
	260	936	55	50	79	55	198	60

This specification text describes the general properties of the product. Texts for variants can be generated with our Easy Product Finder design programme.

Ceiling swirl diffusers with square or circular diffuser face. Supply air and extract air variants for comfort zones. Diffuser face with individually manually adjustable air control blades for horizontal swirling supply air discharge creating high induction levels. For installation into all types of suspended ceilings.

Ready-to-install component which consists of the diffuser face with radially arranged, individually adjustable black or white air control blades, and of a plenum box, equalising element (only supply air variants), side entry or top entry spigot, and suspension holes or suspension lugs.

The diffuser face is fixed to the cross bar with a central screw, concealed by a decorative cap. Spigot suitable for ducts to EN 1506 or EN 13180. Sound power level of the air-regenerated noise measured according to EN ISO 5135.

Special characteristics

- Very low sound power level, ideal for comfort zones
- Individually manually adjustable air control blades
- For all types of ceiling systems, and with an extended border also suitable for freely suspended installation
- Black or white air control blades

Materials and surfaces

- Diffuser face made of galvanised sheet steel
- V, H: Plenum box and cross bar made of galvanised sheet steel

- X: Plenum box made of plastic and galvanised sheet steel
- Air control blades made of plastic, UL 94, V-0, flame retardant
- Lip seal made of rubber
- Exposed diffuser face powder-coated RAL 9010, pure white
- P1: Powder-coated, RAL CLASSIC colour
- Air control blades for supply air similar to RAL 9005, black; extract air variant without air control blades
- Q11: Air control blades for extract air similar to RAL 9005, black
- Q21: Air control blades for supply air and extract air similar to RAL 9010, white

Technical data

- Nominal sizes: 300, 400, 500, 600, 625 mm
- Minimum volume flow rate, with $\Delta t_z = -6$ K:
11 – 47 l/s or 40 – 169 m³/h
- Maximum volume flow rate, with
 $L_{WA} \cong 50$ dB(A): 95 – 315 l/s or 342 – 1134 m³/h
- Supply air to room air temperature difference:
-12 to +10 K

Sizing data

- \dot{V} _____
[m³/h]
- Δp_t _____
[Pa]
- Air-regenerated noise
- L_{WA} _____
[dB(A)]

TDV-SA

TDV-SA – Q – Z – H – M – L / 500 / Q21 / P1 – RAL ...								
1	2	3	4	5	6	7	8	9

1 Type

TDV-SA Swirl diffuser

2 Construction style

R Circular
Q Square

3 System

Z Supply air
A Extract air

4 Connection

H Horizontal
V Vertical

5 Damper blade for volume flow rate balancing

No entry: without damper blade
M With damper blade
MN With cords and pressure tap (only for connection H)

6 Accessories

No entry: without accessories
L With lip seal

7 Nominal size [mm]

300
400
500
600
625

8 Colour of air control blades

No entry: supply air – black air control blades, extract air – no air control blades
Q11 Extract air – black air control blades
Q21 Supply air – white air control blades
Extract air – white air control blades

9 Exposed surface

No entry: powder-coated RAL 9010, pure white
P1 Powder-coated, specify RAL CLASSIC colour

Gloss level
RAL 9010 50 %
RAL 9006 30 %
All other RAL colours 70 %

Order example: TDV-SA-Q-Z-H-MN-L/600/P1-RAL 9016

Construction style	Square
System	Supply air
Connection	Horizontal
Damper blade for volume flow rate balancing	With cords and pressure tap
Accessories	Lip seal
Nominal size	600
Colour of air control blades	Black
Exposed surface	RAL 9016, traffic white, gloss level 70 %

TDV-SA-Q-Z/600

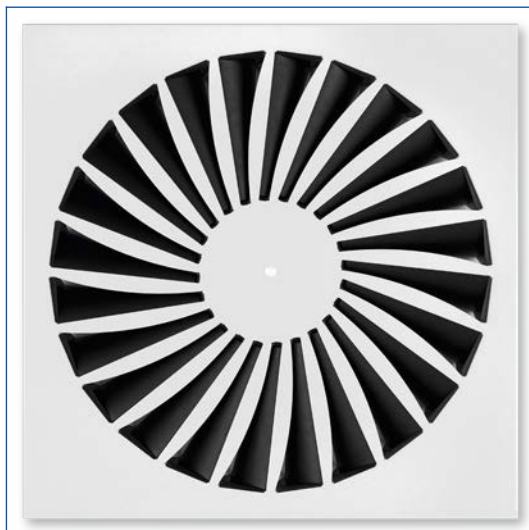

TDV-SA-R-Z/600



TDV-SA-Q-*-H

Variant

- Ceiling swirl diffuser with square diffuser face
- With plenum box for horizontal duct connection

Nominal sizes

- 300, 400, 500, 600, 625

Parts and characteristics

- Square diffuser face
- Plenum box for horizontal duct connection
- Square opening to accommodate the diffuser face
- Equalising element that ensures a uniform airflow through the diffuser face (supply air

variant)

- Simple installation of the diffuser face due to central fixing screw with decorative cap
- Damper blade for volume flow rate balancing (optional)
- Pressure tap and cord-operated damper blade for volume flow rate balancing (optional)
- Lip seal (optional)

Construction features

- Spigot suitable for circular ducts to EN 1506 or EN 13180
- Spigot with groove for lip seal (if accessory lip seal has been ordered)

TDV-SA-Q-*-V

Variant

- Ceiling swirl diffuser with square diffuser face
- With plenum box for vertical duct connection

Nominal sizes

- 300, 400, 500, 600, 625

Parts and characteristics

- Square diffuser face
- Plenum box for vertical duct connection
- Circular opening to accommodate the diffuser face
- Equalising element that ensures a uniform

airflow through the diffuser face (supply air variant)

- Simple installation of the diffuser face due to central fixing screw with decorative cap
- Damper blade for volume flow rate balancing (optional)
- Lip seal (optional)

Construction features

- Spigot suitable for circular ducts to EN 1506 or EN 13180
- Spigot with groove for lip seal (if accessory lip seal has been ordered)

TDV-SA-R-*-H

Variant

- Ceiling swirl diffuser with circular diffuser face
- With plenum box for horizontal duct connection

Nominal sizes

- 300, 400, 500, 600, 625

Parts and characteristics

- Circular diffuser face
- Plenum box for horizontal duct connection
- Circular opening to accommodate the diffuser face
- Equalising element that ensures a uniform airflow through the diffuser face (supply air variant)

- Simple installation of the diffuser face due to central fixing screw with decorative cap
- Damper blade for volume flow rate balancing (optional)
- Pressure tap and cord-operated damper blade for volume flow rate balancing (optional)

- Lip seal (optional)

Construction features

- Spigot suitable for circular ducts to EN 1506 or EN 13180
- Spigot with groove for lip seal (if accessory lip

TDV-SA-R-*-V

Variant

- Ceiling swirl diffuser with circular diffuser face
- With plenum box for vertical duct connection

Nominal sizes

- 300, 400, 500, 600, 625

Parts and characteristics

- Circular diffuser face
- Plenum box for vertical duct connection
- Circular opening to accommodate the diffuser face
- Equalising element that ensures a uniform

airflow through the diffuser face (supply air variant)

- Simple installation of the diffuser face due to central fixing screw with decorative cap
- Damper blade for volume flow rate balancing (optional)
- Lip seal (optional)

Construction features

- Spigot suitable for circular ducts to EN 1506 or EN 13180
- Spigot with groove for lip seal (if accessory lip seal has been ordered)

Square diffuser face with plenum box for horizontal duct connection

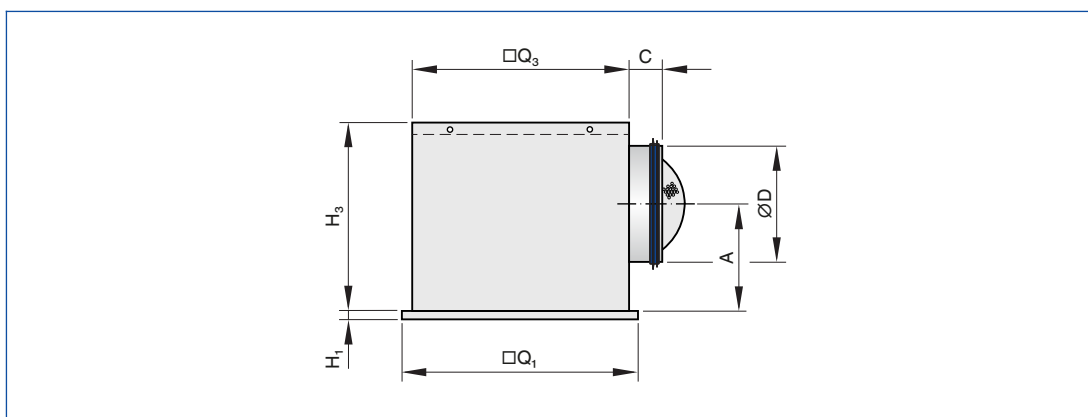

TDV-SA-Q*-H

Nominal size	$\square Q_1$	H_1	$\square Q_3$	H_3	$\varnothing D$	A	C	Plenum box	m
	mm	mm	mm	mm	mm	mm	mm		kg
300	298	8	290	250	158	139	50	AK-Uni-001	3.7
400	398	8	372	295	198	164	50	AK-Uni-002	5.7
500	498	8	476	295	198	164	50	AK-Uni-003	7.8
600	598	8	567	345	248	199	48	AK-Uni-004	10.9
625	623	8	567	345	248	199	48	AK-Uni-004	11.5

Weights apply to the supply air variant

Square diffuser face with plenum box for vertical duct connection

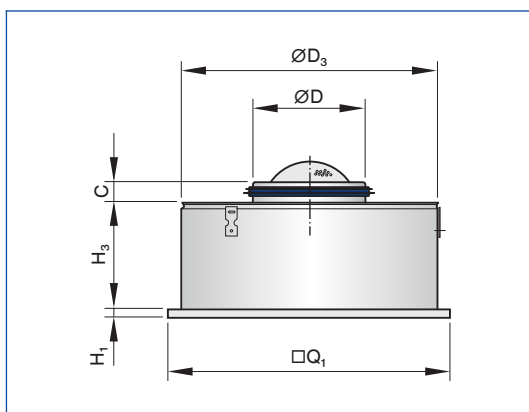

TDV-SA-Q-*-V

Nominal size	$\square Q_1$	H_1	$\varnothing D_3$	H_3	$\varnothing D$	C	m
	mm	mm	mm	mm	mm	mm	kg
300	298	8	275	200	158	50	2.7
400	398	8	364	200	198	50	4.2
500	498	8	462	200	198	50	6.0
600	598	8	559	200	248	48	8.2
625	623	8	559	200	248	48	8.4

Weights apply to the supply air variant

Circular diffuser face with plenum box for horizontal duct connection

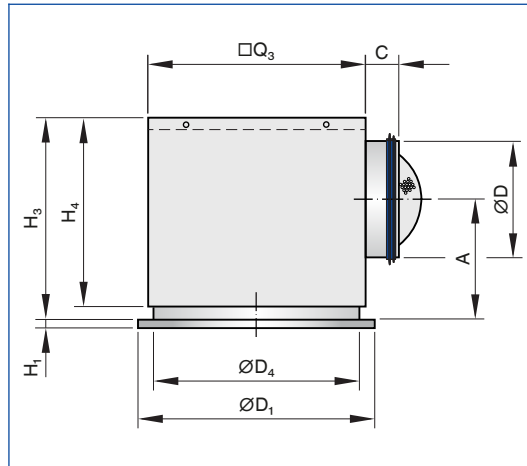

TDV-SA-R-*-H

Nominal size	$\varnothing D_1$	H_1	$\square Q_3$	H_3	$\varnothing D_4$	H_4	$\varnothing D$	A	C	Plenum box	m
	mm	mm	mm	mm	mm	mm	mm	mm	mm		kg
300	300	8	290	285	278	250	158	174	50	AK-Uni-013	4.0
400	400	8	372	330	362	295	198	199	50	AK-Uni-014	6.1
500	500	8	476	330	460	295	198	199	50	AK-Uni-015	8.3
600	600	8	567	380	557	345	248	234	48	AK-Uni-016	11.2
625	625	8	567	380	557	345	248	234	48	AK-Uni-016	11.8

Weights apply to the supply air variant

Circular diffuser face with plenum box for vertical duct connection

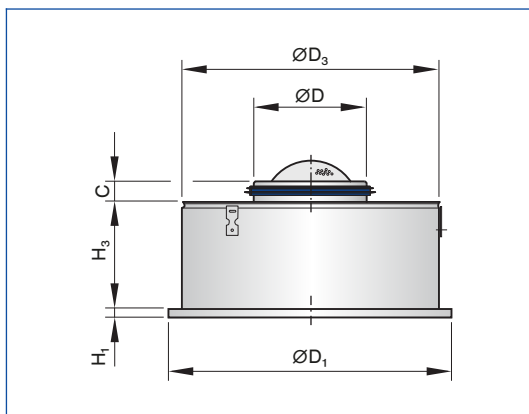

TDV-SA-R*-V

Nominal size	ØD ₁	H ₁	ØD ₃	H ₃	ØD	C	m
	mm	mm	mm	mm	mm	mm	kg
300	300	8	275	200	158	50	2.6
400	400	8	364	200	198	50	4.0
500	500	8	462	200	198	50	5.7
600	600	8	559	200	248	48	7.4
625	625	8	559	200	248	48	7.6

Weights apply to the supply air variant

Diffuser face TDV-SA-Q

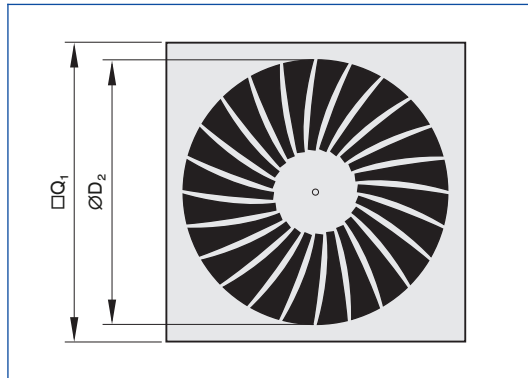

TDV-Q

Nominal size	$\square Q_1$	$\varnothing D_2$	A_{eff}
	mm	mm	m ²
300	298	254	0.0120
400	398	336	0.0210
500	498	440	0.0310
600	598	530	0.0440
625	623	530	0.0440

Diffuser face TDV-SA-R

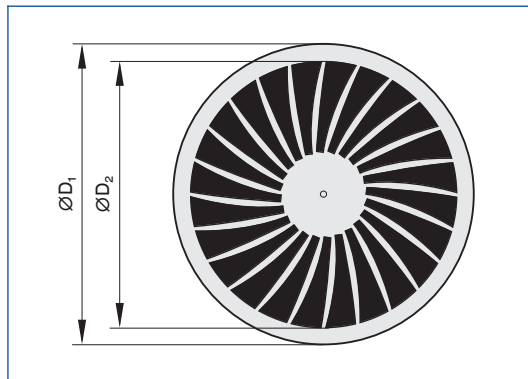

TDV-R

Nominal size	$\varnothing D_1$	$\varnothing D_2$	A_{eff}
	mm	mm	m ²
300	300	254	0.0120
400	400	336	0.0210
500	500	440	0.0310
600	600	530	0.0440
625	625	530	0.0440

Installation in T-bar ceilings



Installation in continuous ceilings



Installation and commissioning

- Preferably for rooms with a clear height up to 4.0 m
- Flush ceiling installation
- Freely suspended installation only with an extended border (supply air variant)
- Horizontal or vertical duct connection
- If necessary, carry out volume flow rate balancing with the damper blade

These are only schematic diagrams to illustrate installation details.

Flush ceiling installation with square plenum box

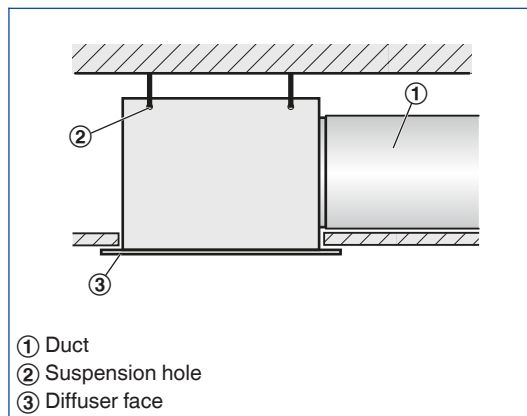

- Horizontal duct connection
- Four suspension holes
- Suspension with cords, wires or hangers, to be provided by others

Freely suspended installation

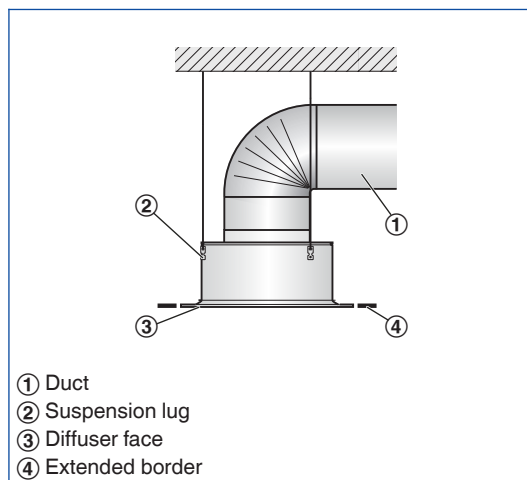

- Vertical duct connection
- Three suspension lugs
- Suspension with cords, wires or hangers, to be provided by others

Diffuser face – sealing

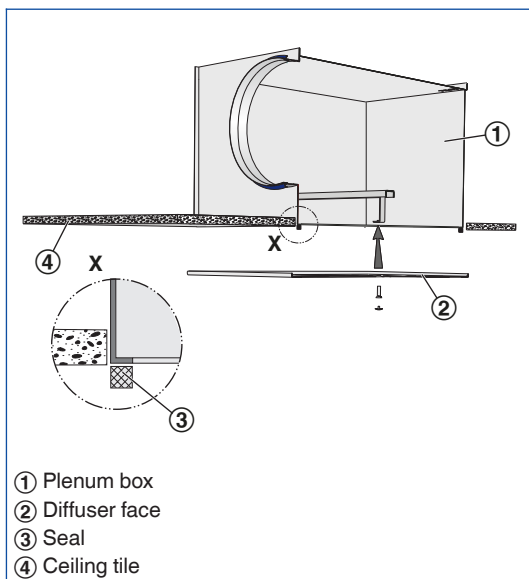

- The self-adhesive sealing tape (supplied) has to be applied to the return edges of the plenum box by others

Diffuser face – central screw fixing

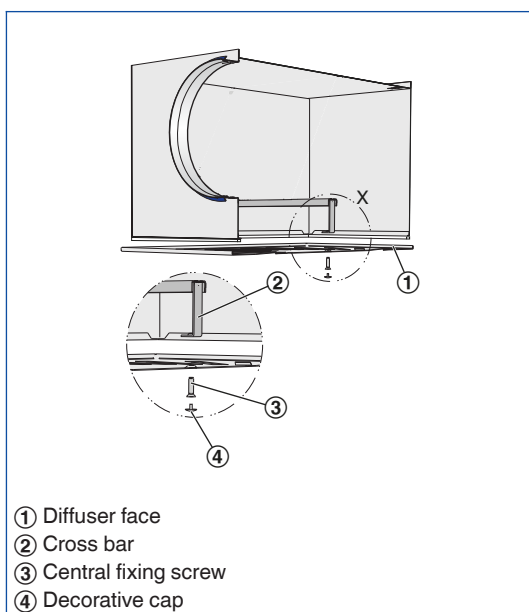

- Using the central fixing screw, fix the diffuser face to the cross bar of the plenum box
- Attach the decorative cap

Ceiling systems

Installation into grid ceilings

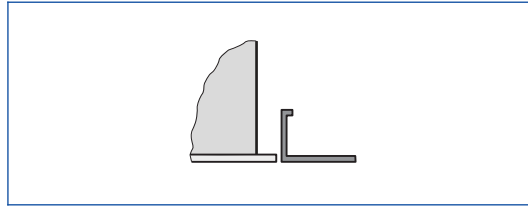

- Fix the plenum box to the ceiling
- The ceiling tile of the grid ceiling is independent of the ceiling diffuser
- Fix the diffuser face after the ceiling has been completed

Installation in continuous ceilings

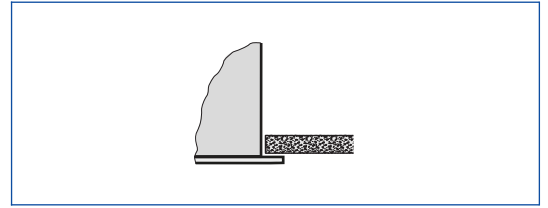

- Fix plenum box (including diffuser face, if necessary) to the ceiling
- Adjust plasterboard ceiling tile as required
- If necessary, fix the diffuser face after the ceiling has been completed

Installation in T-bar ceilings

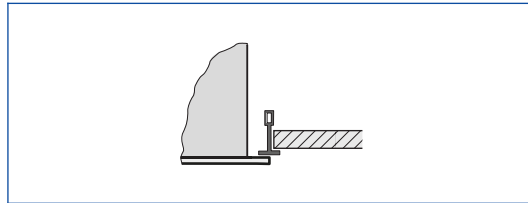

- Fix the plenum box to the ceiling
- The T-bar ceiling is independent of the ceiling diffuser
- Fix the diffuser face below the T-bars after the ceiling has been completed

Volume flow rate balancing

When several diffusers are connected to just one volume flow controller, it may be necessary to balance the volume flow rates.

- Ceiling diffusers with universal plenum box and damper blade (variant -M): The diffuser face can be removed to access the damper blade; the damper blade can then be set to any position between 0 and 90°
- Ceiling diffusers with universal plenum box, damper blade and pressure tap (variant -MN): The diffuser face need not be removed since the damper blade can be set with two cords (white and green).

Volume flow rate measurement

Ceiling diffusers with universal plenum box, damper blade and pressure tap (variant -MN) allow for volume flow rate balancing even with the diffuser face in place.

- Connect the measuring tube to the digital manometer
- Read the effective pressure
- Read the volume flow rate off the characteristic or calculate it
- If necessary, adjust the damper blade position with the cords

A characteristic is included with each AK-Uni plenum box.

AK-Uni-...-MN Volume flow rate balancing

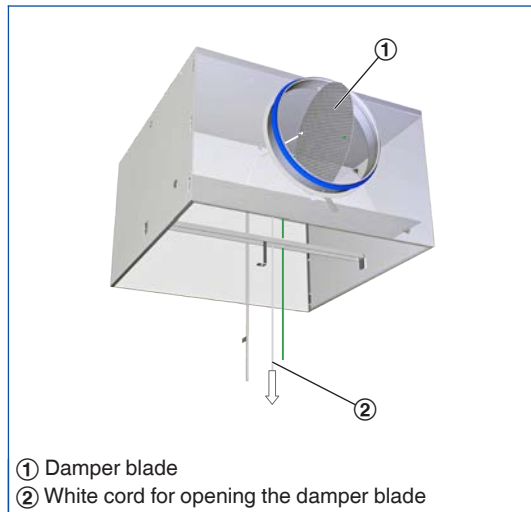

Open, 0°

AK-Uni-...-MN Volume flow rate balancing

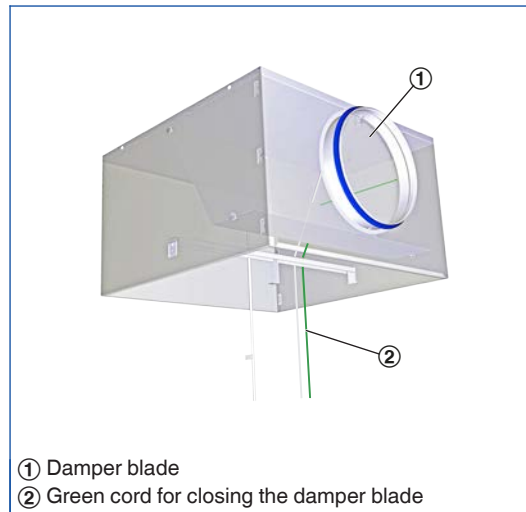

Closed, 90°

AK-Uni-...-MN volume flow rate measurement

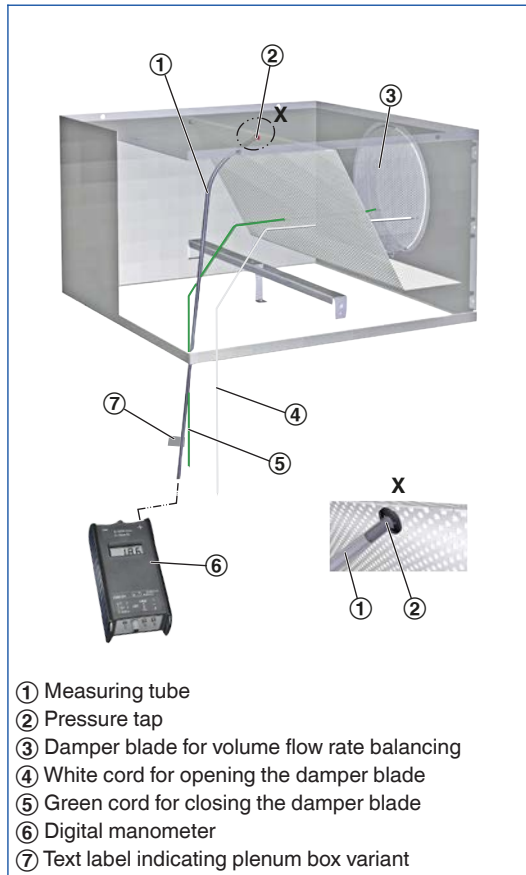

Volume flow rate calculation for air density
1.2 kg/m³

$$\dot{V} = C \times \sqrt{\Delta p_w}$$

Volume flow rate calculation for other air
densities

$$\dot{V} = C \times \sqrt{\Delta p_w} \times \sqrt{\frac{1.2}{\rho}}$$

Principal dimensions

$\varnothing D$ [mm]

Outer diameter of the spigot

$\varnothing D_1$ [mm]

Outer diameter of a circular diffuser face

$\varnothing D_2$ [mm]

Diameter of a circular diffuser face style

$\varnothing D_3$ [mm]

Diameter of a circular plenum box

$\square Q_1$ [mm]

Outer diameter of a square diffuser face

$\square Q_2$ [mm]

Dimensions of a square diffuser face style

$\square Q_3$ [mm]

Dimensions of a square plenum box

H_1 [mm]

Distance (height) from the lower edge of the

suspended ceiling to the lower edge of the diffuser face

H_2 [mm]

Height of a ceiling diffuser, from the lower edge of the suspended ceiling to the upper edge of the spigot

H_3 [mm]

Height of a ceiling diffuser with plenum box, from the lower edge of the suspended ceiling to the upper edge of the plenum box or of the spigot

A [mm]

Position of the spigot, defined by the distance of the spigot centre line to the lower edge of the suspended ceiling

C [mm]

Length of the spigot

m [kg]

Weight

Nomenclature

L_{WA} [dB(A)]

A-weighted sound power level of air-regenerated noise

\dot{V} [m^3/h] and [l/s]

Volume flow rate

Δt_z [K]

Supply air to room air temperature difference, i.e.

supply air temperature minus room temperature

Δp_t [Pa]

Total differential pressure

A_{eff} [m^2]

Effective air discharge area

All sound power levels are based on 1 pW.